

**SD-E10FD**

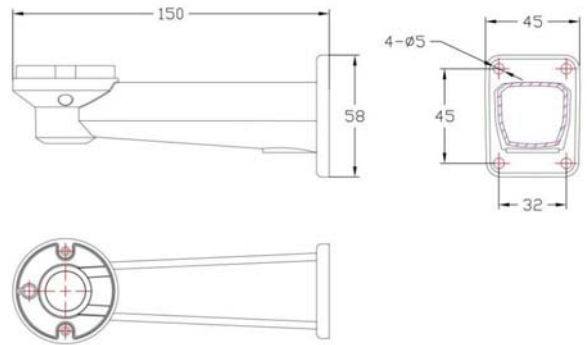

**Product description**

The camera you have purchased is a very innovative product. Yes  
It is a camera  
Similar in concept to a fixed camera, but capable of being panned in all directions and equipped with zoom, also remotely controllable.

**Connections and Mounting**

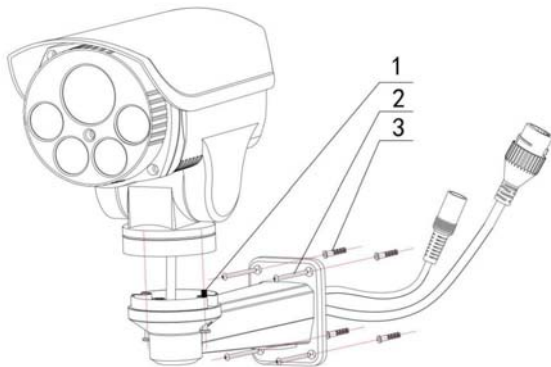

**Bracket Mounting** - The first thing to fasten the bracket supplied separately to the camera body with the two screws provided (1). The cables pass through the bracket and protruding rear.

The camera  
It mounts generally in the output cables so as not to leave exposed wires.  
In the lower part of the bracket is a slot with this seal to allow the cables if they do not originate from walled tubes.

The cameras are to be fixed to the wall and are not suitable for ceiling mounting. Fix the wall bracket with the bolts (3)

**Connections**

The camera is equipped with different connectors: a female BNC for the video, a DC power outlet and two cables (ORANGE / YELLOW) for remote control (RS485).



**BNC video output** - At the BNC female bayonet connecting the video cable that then leads to the DVR typically through RG59 type coaxial cable and BNC connector. You can also use twisted pair cables with balun converters.

**Jack DC12V** - At the power plug must connect a 12VDC power supply stabilized by at least 2,000 mA, such as RE-AL3C model (not included).

The requested plug is the standard 5.5 mm. Attention to use STABILIZED feeders that provide 12V in any load condition. The use of a different supply voltage from 12VDC can generate video disorders and in the worst cases damage the camera. Beware extension power cables are too long or

small section, that could to introduce excessive fall species voltage at the time IR illuminator ignition.

**Telemetry**. It is of the serial connection that leads the movement commands to the camera. The SD series cameras use an RS485 serial line (RS485 BUS) which is formed with a pair of twisted wires.

**ORANGE: RS485 A**  
**YELLOW: RS485B**

Essential that the two cables are wound between them and non-parallel. In principle the RS485 serial line can extend up to 1200 meters in length and along it are connected in cascade devices. The section of the cables closely depends on the length of the connection: for medium distances is sufficient a section of 0.5 mm, while if it is necessary to reach considerable distances (max. 1200 m.) Should be used upper sections of 1 mm or even 2.5 mm.

In carrying out the wiring recommended, but not required to use cable

shielded. The network CAT5 cable containing four twisted pairs is great for the realization of a RS485 BUS. A serial BUS part of rule from a control member which can be a console with joystick or a DVR. The cameras must be connected in cascade ie entering and exiting from the clamps 2 and RS485A RS485B. It 'important not to confuse the two cables (AB) during the connection of the equipment.

The order in which the devices are connected to the BUS has no relevance. Each device will be identified by its own unique address that will properly address the instructions.

It's possible connected to the same BUS up to 256 cameras. The console, do not require any addressing, while for the cameras is necessary to set a different address for each camera, as described below.

**Housing connections - The video connections and** power supply must be protected from the weather and housed in special electrical containers. For this reason, the cameras are equipped with an integrated cable about 50 cm

length to reach the box which goes arranged nearby.

### IR Illuminator

The cameras incorporate within them an infrared illuminator that emanates illumination invisible to the human eye, but visible to the camera. The illuminator turns itself on when it gets dark and the camera switches alone in night vision mode. The illuminator ignition allows the vision in B / N in absolute darkness until its scope lighting. The camera is equipped with 2 levels of lighting that light alone according to the camera zoom.

### AHD versions (SD-E10FD)

These cameras support AHD 1080P technology and to work require AHD DVR 1080p last generation.



The video signal from these cameras does not support CVBS mode and is not visible to older or DVR directly with analog input monitor.

### Versions AHD / CVI / TVI / CVBS (SD-E10FD4)

These cameras support AHD 1080P technology, such as templates

earlier, but in adding even CVI formats TVI 1080P and 1080P used by other manufacturers. They are also able to delivering a video Standard analog CVBS composite to fit the old DVR.



The cameras are equipped with in AHD series 1080P mode, but you can switch the video format recalling the system presets (see page bottom chart).

Before switching the sinceratevi video format that is supported by your DVR'll otherwise the camera unusable

### Control of movement and zoom

The cameras receive commands through the RS485 bus described in the chapter on connections.

The protocol supported is the PELCO P / D standard for which verified that the control member is able to support it. The protocol is automatically learned from the camera is not to be set. The speed of

Protocol and the camera address instead should be personalized with the below listed system presets.

In an RS485 bus it is important that all the cameras and all the command organs share the same communication speed and that each camera has different address.

The camera default setting is as follows:

**PROTOCOL: PELCO P / D in self-learning SPEED ': 2400 baud ADDRESS: 1**

The modification of these parameters is only possible via preset sending for which it is necessary, at least initially set the control member in a consistent manner and verify that you can control the camera in its movements.

### main Settings

#### address Setting

September 85 + 60 + CALL CALL XX (address) To set a new address set the presets 85, immediately after recall preset 60, then call the preset with the address number to be assigned. Ex. 3 to set the address: 85 Set preset, call preset 60 and recall presets 3

#### Setting the baud rate

September 85 + 61 + CALL CALL X set the speed of the protocol (bit rate) set the presets 85, immediately after recall preset

61, then a preset among these: 1 - Set Bit Rate 2400 2 - Set bit rate 4800 3 - Set bit rate 9600

Ex. To set speed 9600: Set preset 85, preset 61 call and recall presets 3

### Programming Menu OSD

These cameras allow you to configure various display options through an on-screen menu (OSD). To open the on-screen menu, you must call the PRESET 95, move with the arrow keys and confirm with the IRIS + command.

This camera does not support the control via UTC.

### OSD Options

For explanations of the various OSD options refer to the separate instructions.

### Preset

The camera can store predefined positions denominated PRESET recallable at pleasure. To set a preset and recall a preset follow the instructions of the control unit (DVR / Console)

### System Preset

The camera can manage 256 presets, but only 220 are available to the user because the preset 65-100 are reserved for special functions which we illustrate in the following table:

FUNCTION	PRESET	FURTHER INFORMATION
Set address	<b>September 85</b> <b>CALL 60 CALL</b> <b>N</b>	N = address of the camera on the RS485 BUS (1..256)
Set baud rate	<b>SET 85 61</b> <b>CALL CALL N</b>	2400 baud N = 1 N = 2 N = 3 4800 baud 9600 baud
Set video output	<b>September 85</b> <b>CALL 62 CALL</b> <b>N</b>	N = 1 AHD PAL (DVR DSE) N = 2 N = 3 TVI AHD NTSC PAL (DVR HIKVISION) N = 4 N = 5 CVI TVI NTSC PAL (DVR DAHUA) N = 6 CVI NTSC N = 7 PAL CVBS (DVR COMPOSITE VIDEO) N = 8 CVBS NTSC
Home Function	<b>September 85</b> <b>CALL 75 CALL</b> <b>N</b>	It sets the automatic function in which the camera automatically returns after a certain time of inactivity. N = 1 N = No HOME position Preset 1 2 N = 3 N = 4 1 Autoscan Tour 1 N = 5 Pattern 1
Tempo Home	<b>September 85</b> <b>CALL 76 CALL</b> <b>N</b>	It sets the idle time after which the camera returns to the home set above function. N = 1..60 minutes
IR illuminators Control	<b>September 85</b> <b>CALL 70 CALL</b> <b>N</b>	It sets the power mode of IR illuminators. N = 1 Automatic ignition N = 2 N = 3 Always on Always off
illuminators with zoom power to a minimum (close)	<b>September 85</b> <b>CALL 71 CALL</b> <b>N</b>	N = 1..10
illuminators Power Zoom maximum (away)	<b>SET 85 72</b> <b>CALL CALL N</b>	N = 1..10
Ignition Sensitivity IR illuminators	<b>September 85</b> <b>CALL 73 CALL</b> <b>N</b>	Defines the threshold power of the illuminators N = 1..10 (a lower value corresponds ignition with less brightness)
left scan limit	<b>September 92</b>	As linear SCAN defines the horizontal continuous movement of the camera between two end points with the same level of TILT. With this preset you set the left limit of the scan
Right scan limit	<b>September 93</b>	With this preset you set the right limit of scan
speed scan	<b>September 85</b> <b>CALL 77 CALL</b> <b>N</b>	It defines the speed of horizontal scanning N = 1..50
Start scan	<b>CALL 99</b>	With this preset starts the horizontal scan
Stop scan	<b>CALL 96</b>	With this preset stops the horizontal scanning
Preset Home Tour	<b>September 85</b> <b>CALL 50 CALL</b> <b>N</b>	As TOUR or CRUISE means the sequential display of more preset with a certain residence time on each one. Of the camera factory performs the tour between preset from 1 to 10 with a residence time on each preset to 10 seconds. Here you can set a different preset start from preset 1 N = Preset start tour
Preset final tour	<b>SET 85 51</b> <b>CALL CALL N</b>	Here you can set the preset end of the tour (Factory 10) N = Preset end tour
Residence time of the tour	<b>September 85</b> <b>CALL 52 CALL</b> <b>N</b>	Here you can set the dwell time of each preset during the tour (10 seconds Factory) N = 1..255 seconds

Start tour	CALL 98	With this preset you start the tour
Stop tour	CALL 96	With this preset stops the tour
Start recording Pattern	September 86	A PATTERN is a sequence of movements prestored callable at any time. With this command, it starts the recording of the sequence. E 'can then record the sequence of movements and zoom at will.
Recording End Pattern September 96		With this command, it terminates the recording of the pattern sequence
Start pattern	CALL 97	With this preset you start the pattern
Stop pattern	CALL 96	With this preset stops the pattern
Opens menu Camera Module	CALL 95	With this preset you access the OSD setup menu of the camera.

#### Main technical data



[www.dseitalia.it/dati\\_speed-dome.htm](http://www.dseitalia.it/dati_speed-dome.htm)

